

NISSAN NAVARA 2016>

KOD / CODE : 5026DKA112

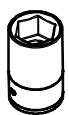

SW15 (30Nm)

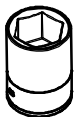

SW19 (50Nm)

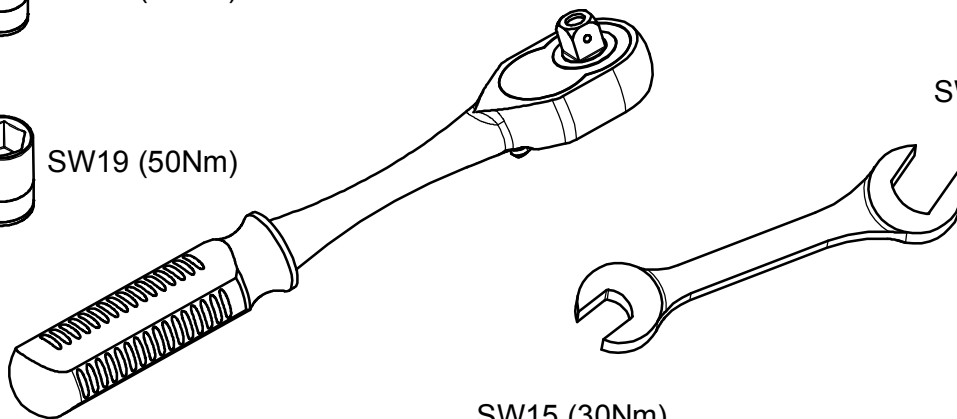

SW15 (30Nm)

SW19 (50Nm)

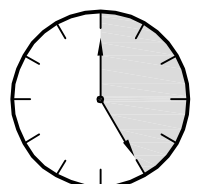

MONTAJ SETİ / INSTALLATION SET

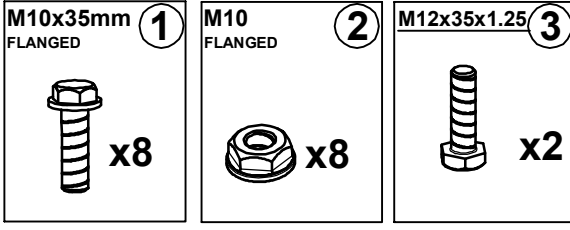

1. M10x35mm FLANŞLI CİVATA / *M10x35 BOLT FLANGED*
2. M10 FLANŞLI SOMUN / *M10 NUT FLANGED*
3. M12x35x1.25 mm. CİVATA / *M12x35x1.25 mm. BOLT*

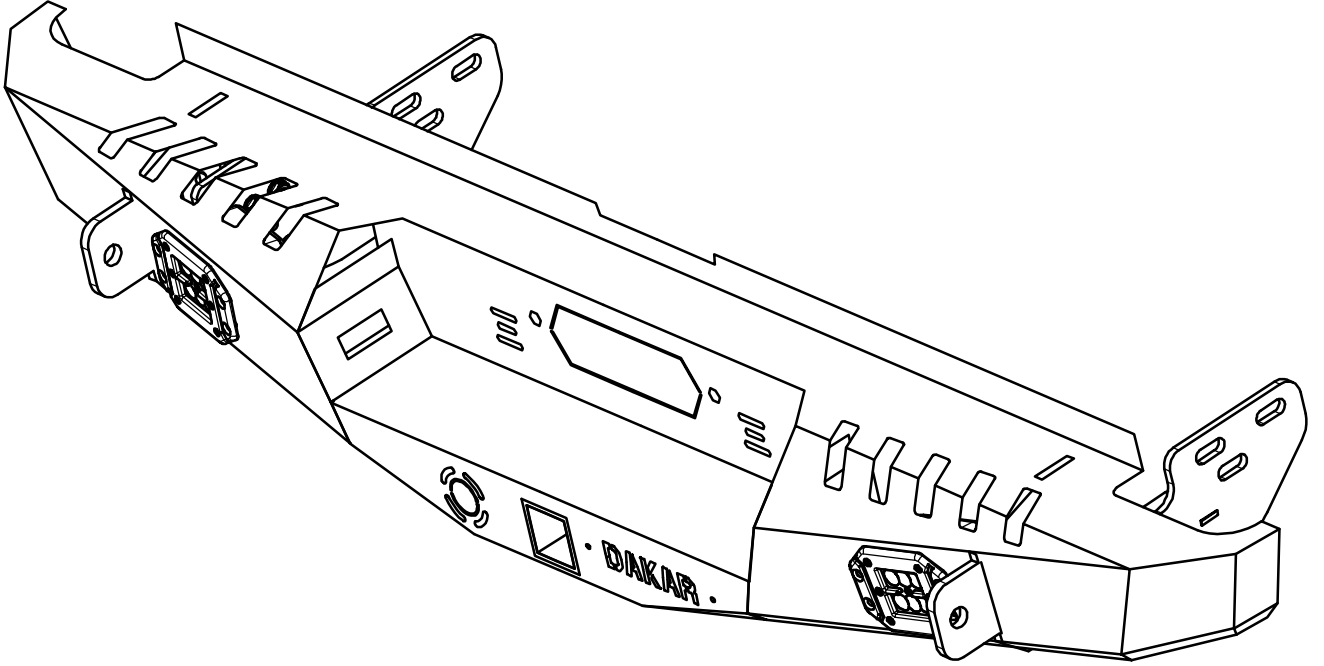
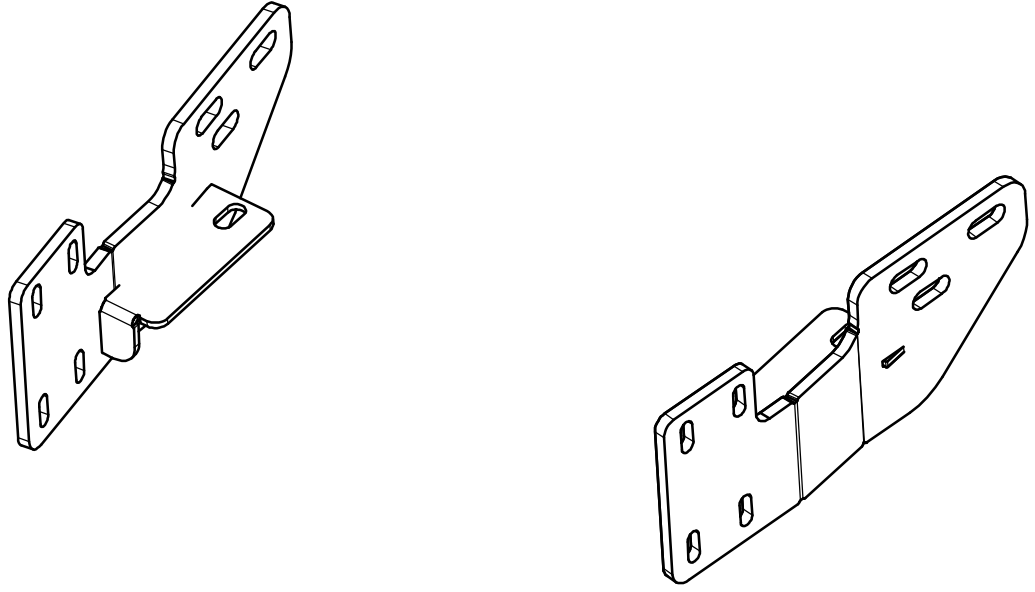

Fig. 1



BRAKETİ CİVATALAR 3-4 ile MONTAJLAYINIZ

INSTALL THE BRACKET WITH BOLTS

Fig. 2

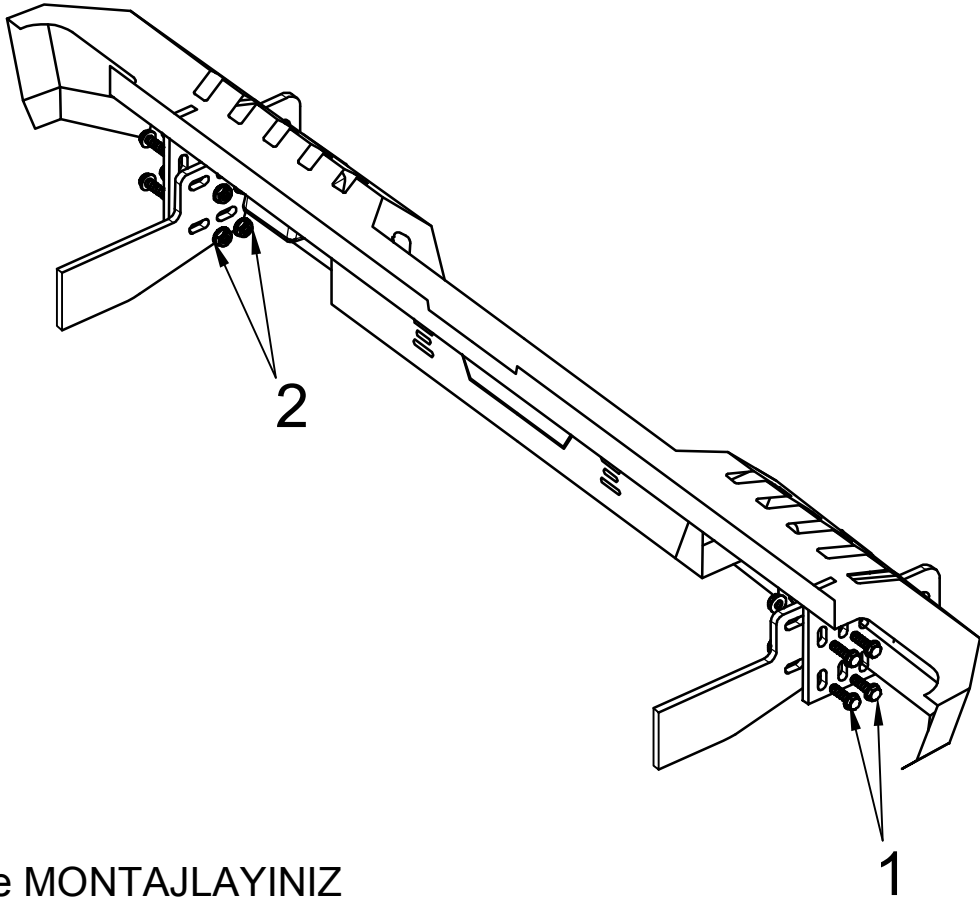

ÜRÜNÜ 1-2 ile MONTAJLAYINIZ

PLEASE INSTALL THE PRODUCT



MONTAJ ŞEMASI / INSTALLATION SCHEME

